

KOMET KomTronic[®] U-Axis system

**Economic turning contours on the machining centre
when working with a stationary workpiece**

KOMET KomTronic® U-Axis system

Replaces separate machining on a lathe

Benefits for you:

■ Lower investment costs

- Use of standard instead of special machines
- Reduction in number of tools
- No need for clamping devices for finish machining on turning machines

■ Reduced unit costs

- Complete machining on one machine.
- Reduction in machining and throughput times
- Savings on tool changes
- Replacement of time consuming circular machining operations
- Reduced holding times
- High cutting capacity

■ Lower operating costs

- Complete machining on one machine without the workpiece being rotated
- Minimum power consumption because of U-Axis systems

Machining examples



Grooving

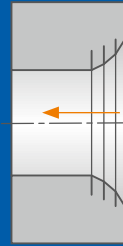

Turning valve seats

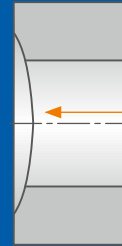

Undercutting differential housing

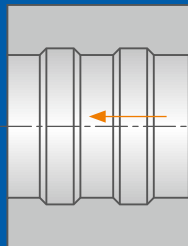
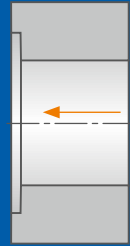

Bore with coolant passages

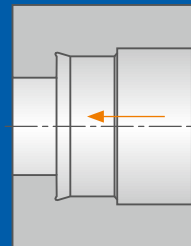

Bearing seat

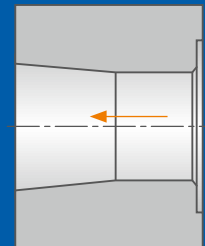

Tie rod

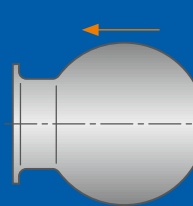

Contour turning, external and internal contour turning

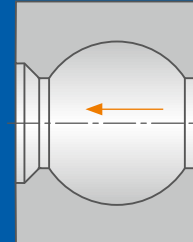

Tool-changeable NC axes for machining centres:

The freely programmable KomTronic® U-Axis system make any contour and turning operations possible on non-rotationally symmetrical parts. Combined with custom-made front tools and the optimum selection of inserts, contours in bores and external machining operations can be successfully carried out. This allows a considerable reduction in production times, with better surface quality and greater accuracy of form. Further savings in time and costs can also be achieved by reducing the number of tools previously required - for example, circular milling a complex internal contour with various form milling tools. The saving in form milling tools and tool changes this achieves also reduces production time and production costs.

Greatly reduced processing times and higher precision

KomTronic® U-Axis systems essentially consist of one compact facing head with single slide that is driven by a servo motor and threaded spindle. The power supplied to the electronics and the drive is transmitted contact-free and inductively to the U-Axis system. Similarly, the data is exchanged inductively with the U-Axis system. A so-called stator is mounted on the spindle side. It is segment-shaped, which permits the U-Axis tools to be changed in and out automatically. The ring-shaped inductive transmission unit on the U-axis side ensures proper data and energy exchange in every angular position. Thanks to the freely programmable cutting edge that is dynamically adjustable during machining, the mechatronic U-Axis systems are automatically changeable NC-axes. Programming is carried out in the usual NC programming language with all its functions and is integrated into the machine control system.

We are also pleased to answer questions via e-mail at KomTronic@kometgroup.com.

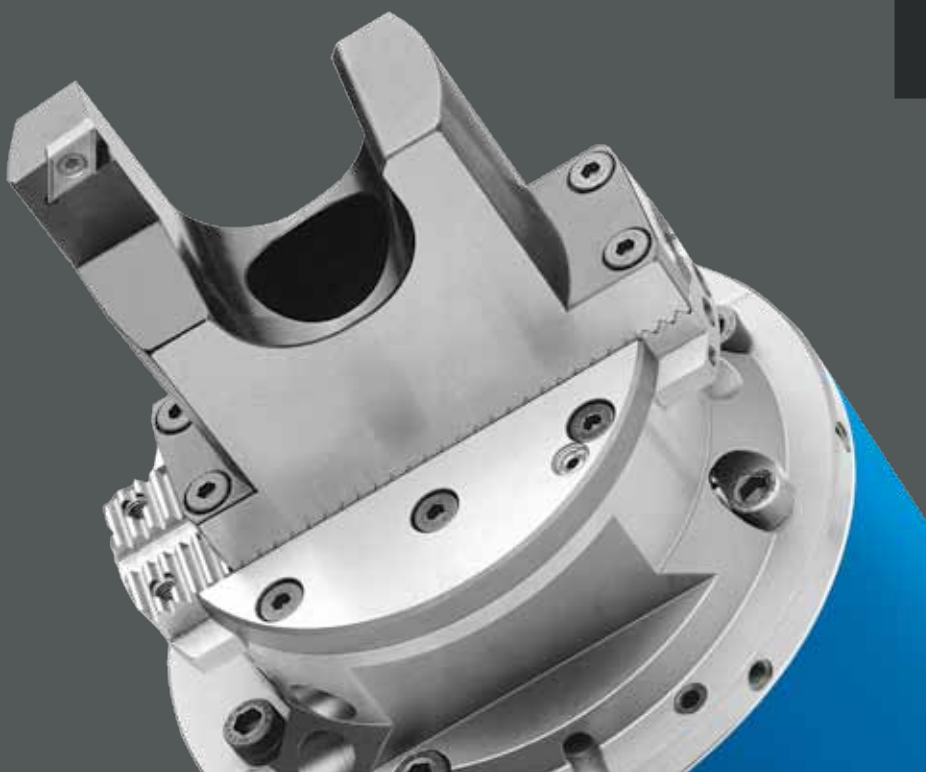

KOMET KomTronic® U-Axis system

The u-axis for tool changing

UAS-125-Z-12

Technical data

- U-Axis tool 12 mm stroke with toothed tool connection
- external diameter: 125 mm
- weight: 7,6 kg (with HSK63)
- max. feed: 200 mm/min
- max. spindle speed: 1020–4000 min⁻¹, depending on slide position (see stroke/spindle speed diagram)
- with internal coolant: 40 bar

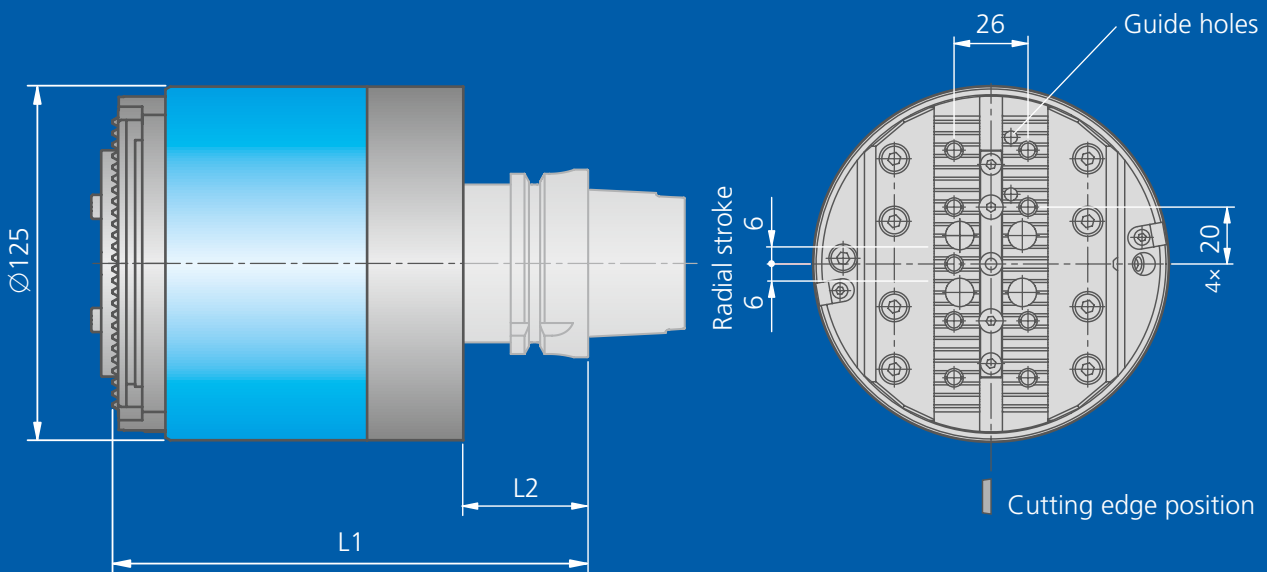

UAS-125-Z-12				
Order No.	Article	Connection	L1	L2
E11 10050	UAS-125-HSK63-E-Z-12-1a	HSK63	166	42
E16 10080	UAS-125-SK40-E-Z-12-1a	SK40	159	35
E16 10090	UAS-125-CAT40-E-Z-12-1a	CAT40	159	35
E16 10100	UAS-125-BT40-E-Z-12-1a	BT40	166	42

Max. stroke/spindle speed diagram

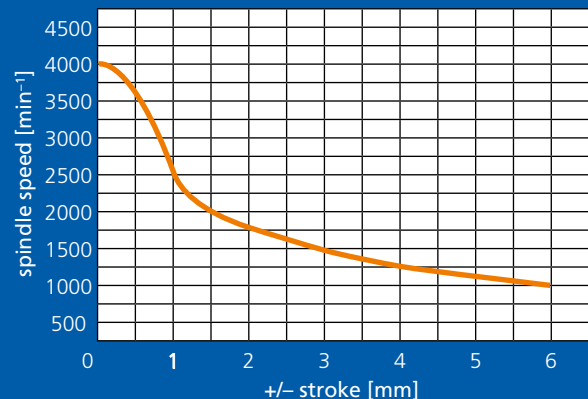

See page 18 for more application details!

Protection class: IP67

Operating modes: full NC axis for interpolation

It's not possible to use the system UAS-125-Z-12 and UAS-115-Z-22 together in the same machine!

Together with KOMET front tooling and KOMET inserts, the KomTronic® U-Axis system opens up machining possibilities which until now would have been unthinkable on a machining centre.

KOMET KomTronic® U-Axis system

The u-axis for tool changing



UAS-115-Z-22

Technical data

- U-Axis tool 22 mm stroke with toothed tool connection
- external diameter: 115 mm
- weight: 6,4 kg (with HSK63)
- max. feed: 350 mm/min
- max. spindle speed: 750–4000 min⁻¹, depending on slide position (see stroke/spindle speed diagram)
- with internal coolant: 40 bar

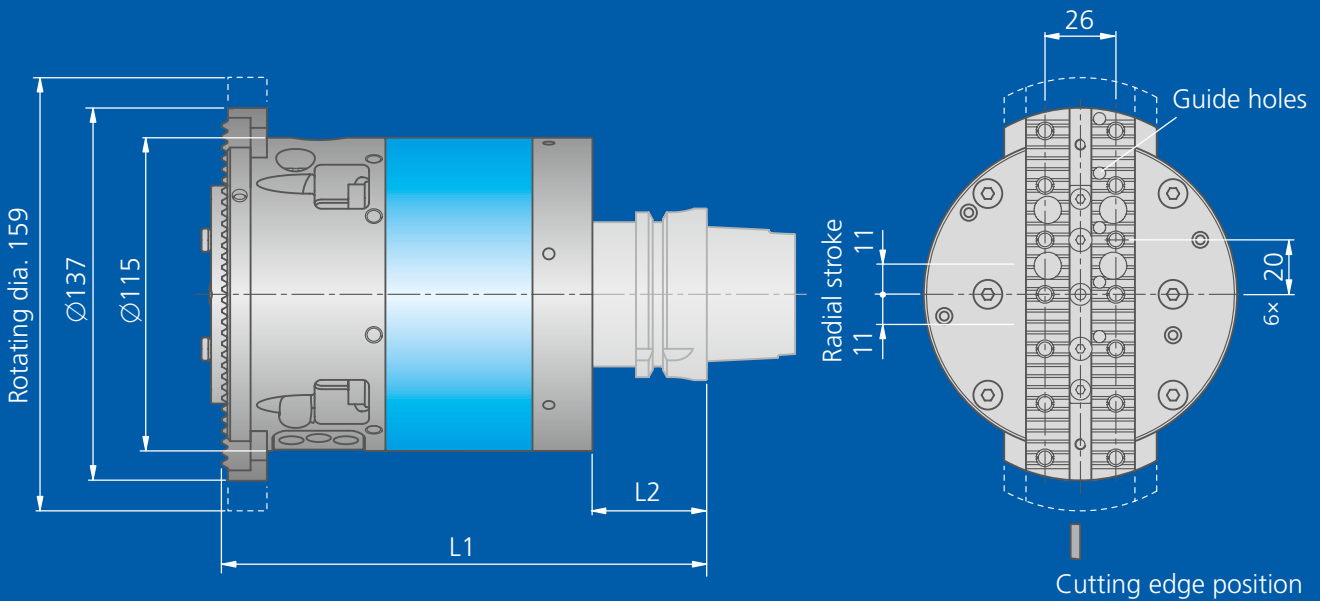

UAS-115-Z-22				
Order No.	Article	Connection	L1	L2
E21 20010	UAS-115-HSK63-E-Z-22-2	HSK63	178	42
E21 22010	UAS-115-SK40-E-Z-22-2	SK40	171	35
E21 24010	UAS-115-CAT40-E-Z-22-2	CAT40	171	35
E21 26010	UAS-115-BT40-E-Z-22-2	BT40	178	42

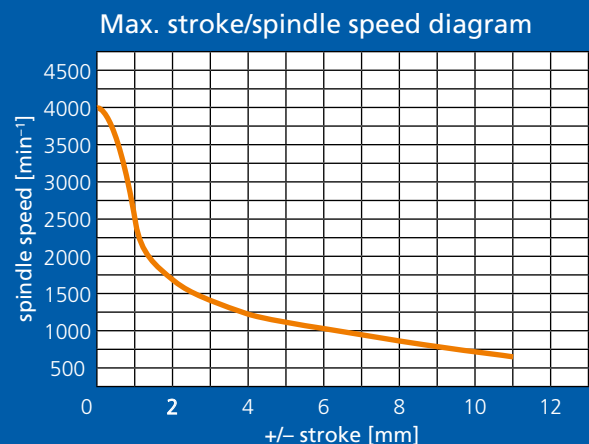

See page 18 for more application details!

Protection class: IP67

Operating modes: full NC axis for interpolation

It's not possible to use the system UAS-115-Z-22 and UAS-125-Z-12 together in the same machine!

Together with KOMET front tooling and KOMET inserts, the KomTronic® U-Axis system opens up machining possibilities which until now would have been unthinkable on a machining centre.

KOMET KomTronic® U-Axis system

The u-axis for tool changing

UAS-160-Z-22

Technical data

- U-Axis tool 22 mm stroke with toothed tool connection
- external diameter: 160 mm
- weight: 14,2 kg (with HSK100)
- max. feed: 250 mm/min
- max. spindle speed: 750–4000 min⁻¹, depending on slide position (see stroke/spindle speed diagram)
- with internal coolant: 40 bar

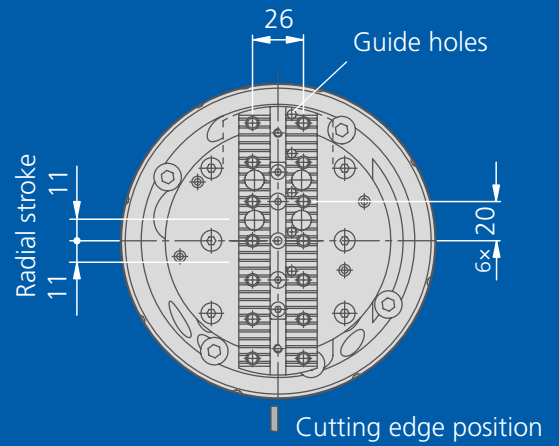
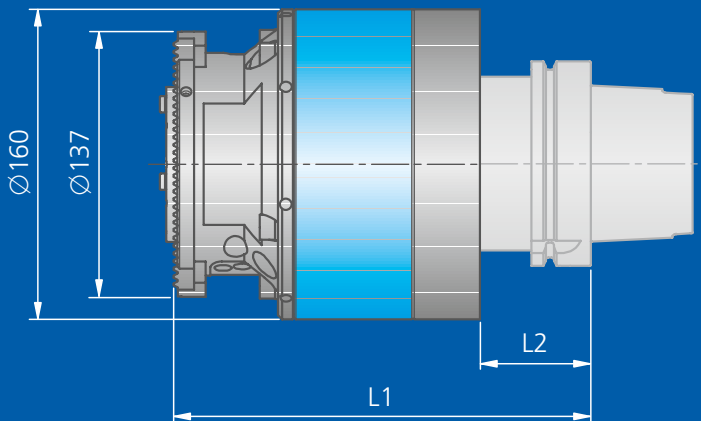

UAS-160-Z-22				
Order No.	Article	Connection	L1	L2
E21 31010	UAS-160-HSK100-E-Z-22-1	HSK100	203,5	45
E21 33010	UAS-160-SK50-E-Z-22-1	SK50	193,5	35
E21 35010	UAS-160-CAT50-E-Z-22-1	CAT50	193,5	35
E21 37010	UAS-160-BT50-E-Z-22-1	BT50	211,5	53

Max. stroke/spindle speed diagram

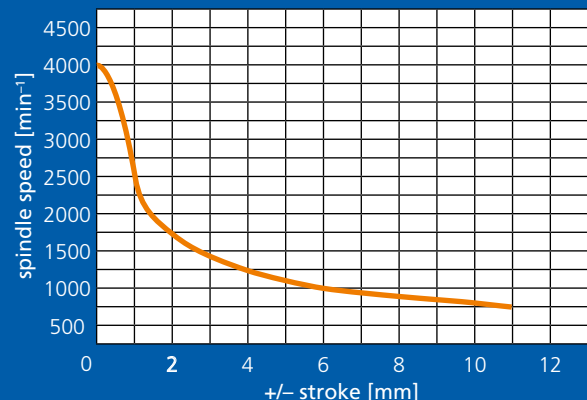

See page 18 for more application details !

Protection class: IP67

Operating modes: full NC axis for interpolation

Together with KOMET front tooling and KOMET inserts, the KomTronic® U-Axis system opens up machining possibilities which until now would have been unthinkable on a machining centre.

KOMET KomTronic® U-Axis system

The u-axis for tool changing



UAS-160-Z-50

Technical data

- U-Axis tool 50 mm stroke with toothed tool connection
- external diameter: 160 mm
- weight: 13,3 kg (with HSK100)
- max. feed: 250 mm/min
- max. spindle speed: 560–4000 min⁻¹, depending on slide position (see stroke/spindle speed diagram)
- with internal coolant: 40 bar

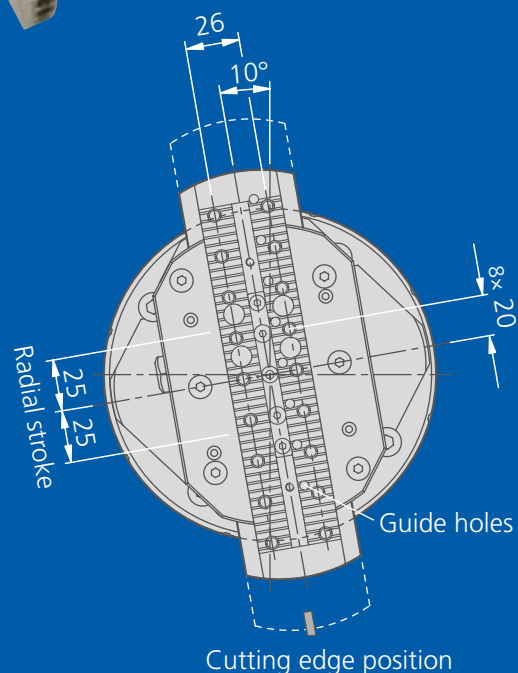
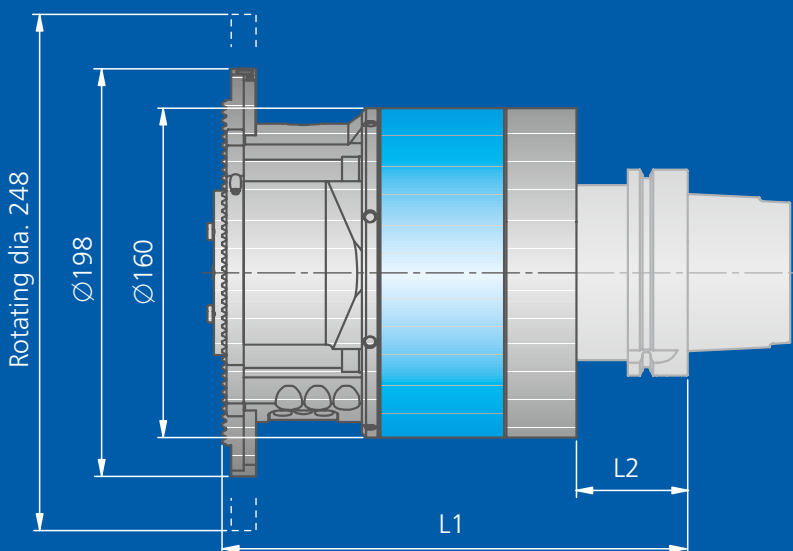

UAS-160-Z-50				
Order No.	Article	Connection	L1	L2
E21 31020	UAS-160-HSK100-E-Z-50-1	HSK100	217,5	45
E21 33020	UAS-160-SK50-E-Z-50-1	SK50	207,5	35
E21 35020	UAS-160-CAT50-E-Z-50-1	CAT50	207,5	35
E21 37020	UAS-160-BT50-E-Z-50-1	BT50	225,5	53

Max. stroke/spindle speed diagram

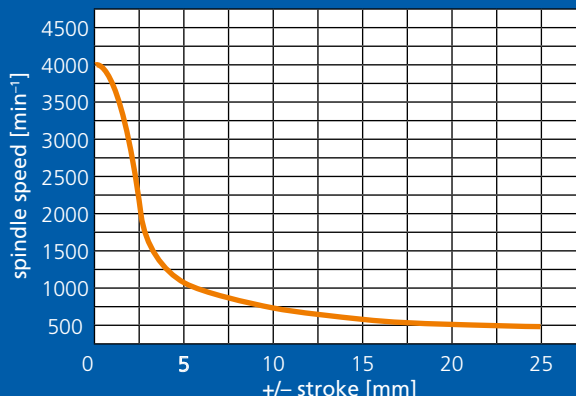

See page 18 for more application details !
 Protection class: IP67
 Operating modes: full NC axis for interpolation

Workpieces can be completely machined with high precision and cycle time savings utilising these options for turning, undercutting, chamfering and generation of NC controlled contours.

Patents applied for.

KOMET KomTronic® U-Axis system Machining examples

Workpiece: differential housing

Benefits for you:

- Flexibility
- Saves on expensive blanking
- Replaces separate machining on a lathe and thus eliminates the need for a clamping device
- Increase in quality



Machining: turning an inside radius

Cutting speed $v_c = 80 \text{ m/min}$
Feed $f = 0,1 \text{ mm/rev.}$
Cutting width 1st cut $a_p = 1,5 \text{ mm}$
2nd cut $a_p = 0,2 \text{ mm}$

Radial stroke 10 mm

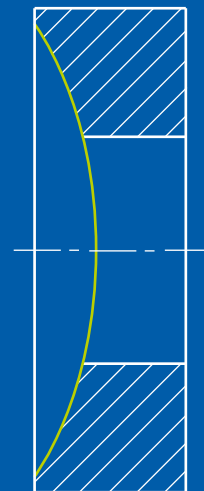

Machining: rear planing

Cutting speed $v_c = 80 \text{ m/min}$
Feed $f = 0,12 \text{ mm/rev.}$
Cutting width $a_p = 0,3 \text{ mm}$

Radial stroke 14,5 mm

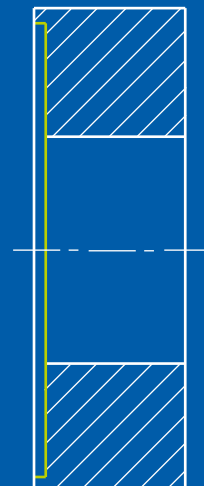



Workpiece: control block

Machining:
turning an inside taper

Benefits for you:

- Replaces separate machining on a lathe and thus eliminates the need for a clamping device
- Reduced production times
- Increase in quality

The material Inconel 625 was applied to a tapered hole and machined in 2 cuts.

Cutting speed $v_c = 30$ m/min
Feed $f = 0,08$ mm/rev.
1st cut $a_p = 2,5$ mm
2nd cut $a_p = 0,5$ mm

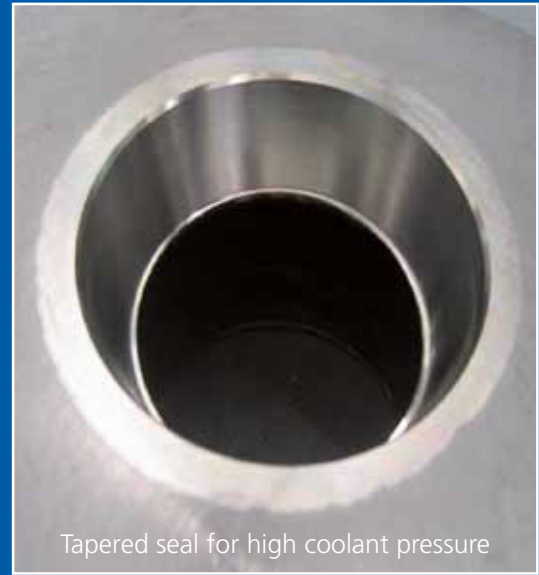

Workpiece: wheelmount

Machining: reverse taper machining

Benefits for you:

- Complete machining on one machine
- Replaces separate machining on a lathe and thus eliminates the need for a clamping device
- Reduced processing times
- Increase in quality

Cutting speed $v_c = 150$ m/min
Feed $f = 0,08$ mm/rev.
Taper angle $\alpha = 9,5^{\circ}_{-0,05^{\circ}}$
Material: Cast aluminum

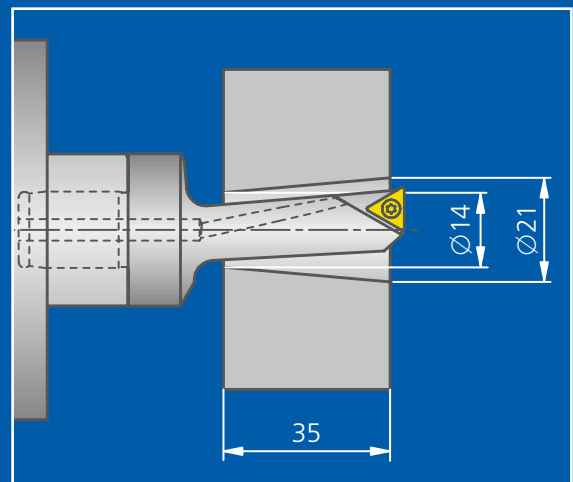

KOMET KomTronic® U-Axis system Machining examples

Workpiece: bearing plate

Machining: turning a bearing plate

Benefits for you:

- Reduced processing time
- Reduced tool change time
- Reduced tool costs
- Complete machining
- Flexibility
- Higher precision and process reliability

Material 42CrMo4

Variable diameter



Workpiece: control block

Machining: complete machining on one turning/milling centre

Benefits for you:

- Reduced production time
- Reduced tool costs
- Flexibility
- Increase in quality

Material 42CrMo4



Workpiece: control block

Machining: turning an outer contour

Benefits for you:

- Complete machining on one machining centre
- Replaces separate machining on a lathe and thus eliminates the need for a clamping device
- Reduced production times
- Increase in quality

Material: Inconel

Workpiece: Brake caliper

Machining: reaming and recessing in one operation

Benefits for you:

- Complete machining on one machine
- Reduced processing time
- Reduced tool costs
- Reduced additional costs
- Flexibility
- Increase in quality

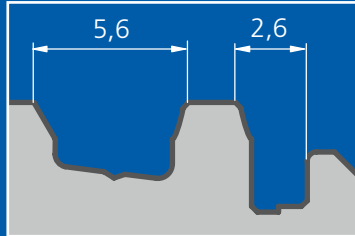

Material: GGG50

Reaming:	Cutting speed	$v_C = 130 \text{ m/min}$
	Feed	$f = 0,15 \text{ mm/rev.}$
Grooving:	Cutting speed	$v_C = 100 \text{ m/min}$
	Feed	$f = 0,06 \text{ mm/rev.}$

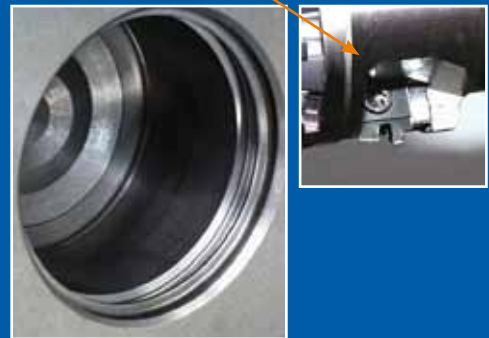

Workpiece: joint plate

Machining: taper machining with radius contour

Benefits for you:

- Reduced processing time
- Reduced tool costs
- Reduced production time
- Higher quality and process reliability



Material: Titan

Cutting speed	$v_C = 50 \text{ m/min}$
Feed	$f = 0,05 \text{ mm/rev.}$

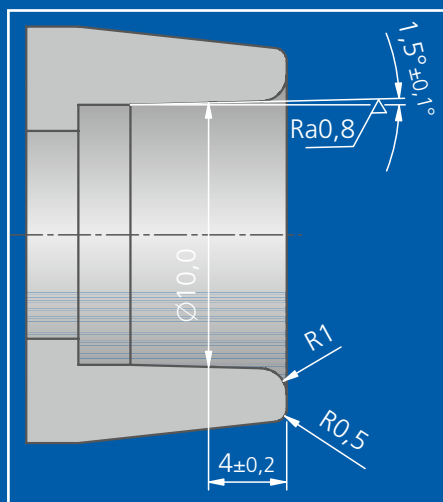

KOMET KomTronic® U-Axis system Machining examples

Workpiece: hydraulic cylinder

Machining: springing valves
Boring inner contours and recesses with
2 U-axis systems

Benefits for you:

- Reduced processing times
- Reduced tool change times
- Reduced tool costs
- Reduced additional costs
- Flexibility

Material: X12CrMoS17

Feed
 $f = 0,1-0,15 \text{ mm/rev.}$
Spindle speed
 $n = 2000 \text{ min}^{-1}$

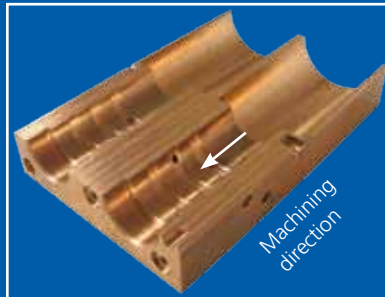

Workpiece: cylinder head

Machining: central bore of the cylinder heads of a
diesel engine

Benefits for you:

- Increased precision and process reliability
- Replaces circular milling operations
- Time saving of 80 %

Material: GGG50

$\varnothing 66,6^{+0,15} \text{ mm}$

Cutting speed
 $v_C = 120 \text{ m/min}$
Feed
 $f = 0,1 \text{ mm/rev.}$
Cutting width
 $a_p = 0,65 \text{ mm}$

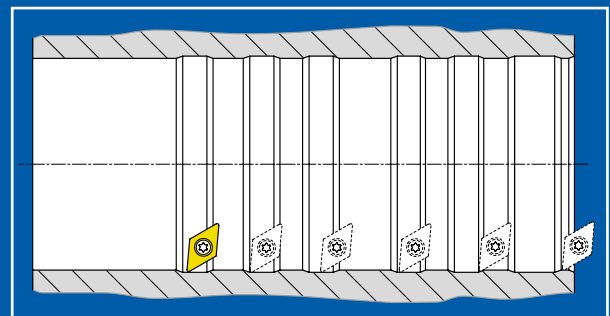

Complete machining in a closed process chain Turning and measuring on the machining centre

- Complete machining: turning on a milling machine, no switching to a turning machine, thus eliminating the need for a clamping unit
- Reduction in number of tools, no special forming tools
- Higher quality
- Precision measuring with direct measuring using a barrel gauge or calliper
- Automatic test cut possible

Benefits for you:

- Time saving
- Saving on tools
- Increase in quality
- Automatic wear compensation
- No holding times

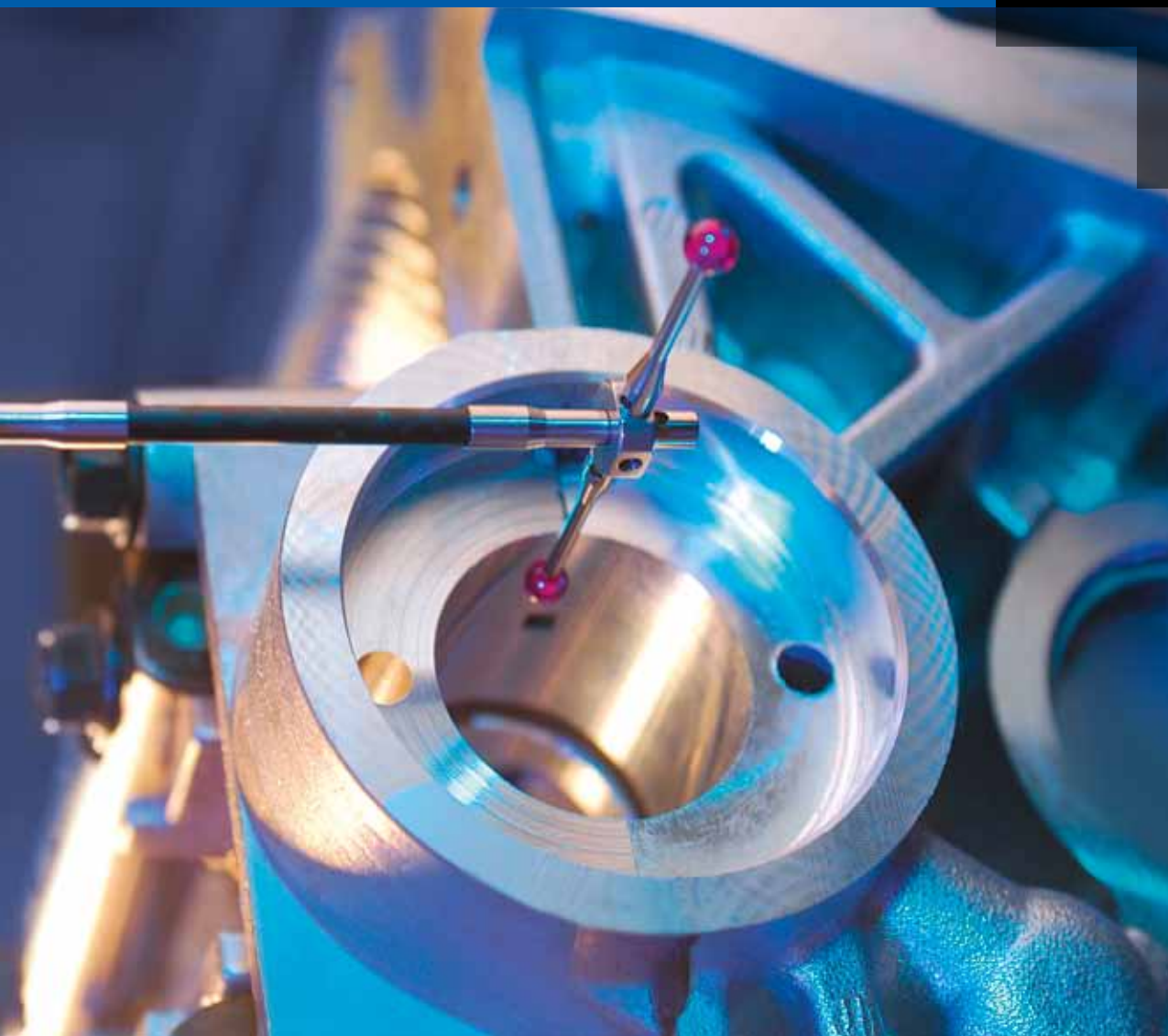

KOMET KomTronic® U-Axis system Modular systems: modular tool holders

The front tool can be mounted directly onto the slide. The following adaptors are available when using standard tools (others available on request):

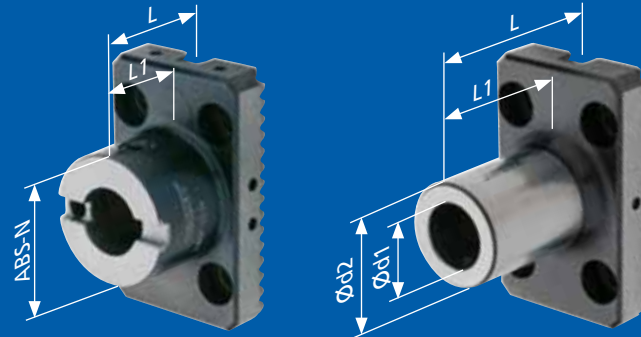

	Order No.	Ø d1	Ø d2	L	L1
	P80 23030	ABS 32 N	32	33	23,5
	P80 24030	ABS 40 N	40	37	27,5
	P80 25030	ABS 50 N	50	42	28
	P81 21010	Ø 16	25,8	46,5	37
	P81 21020	Ø 20	40	51,5	42
	P81 21030	Ø 25	48	76	62
	P81 21040	Ø 32	52	76	62

Nothing new
for programming ...

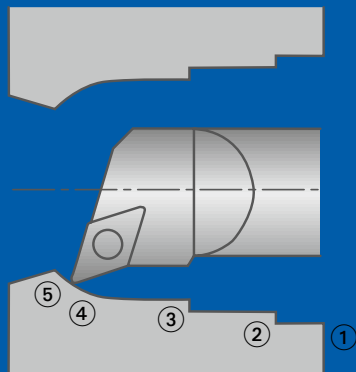

G0 U15		
G1 Z0		
G1 U14.5 Z-0.5	①	corner break
G1 Z-6		
G1 U14	②	step
G1 U13.75 Z-6.25	②	corner break
G1 Z-17		
G1 U13.5	③	step
G1 Z-25		
G3 Z-34.18 U9.9 E13.5	④	radius
G1 Z-42 U12	⑤	angle
G0 U9.75		
G0 Z10		

Integration of the KomTronic® U-Axis system into different machine control systems

Control system	Manufacturer
SINUMERIK 840 C	SIEMENS
SINUMERIK 840 D	
SINUMERIK 840 Di sl	
Fanuc 15i / 16i / 18i / 21i / 150i / 160i / 180i / 210i	FANUC
Fanuc 30i / 31i / 32i / 300i / 310i / 310is / 320i	
Heidenhain TNC 426/TNC 430	HEIDENHAIN
Heidenhain iTNC 530	
MillPlus	
INDRAMAT MTC-200 V18	INDRAMAT
INDRAMAT MTX	
Mazatrol Matrix	MAZAK

KOMET KomTronic® UAS-125

Schematic system overview

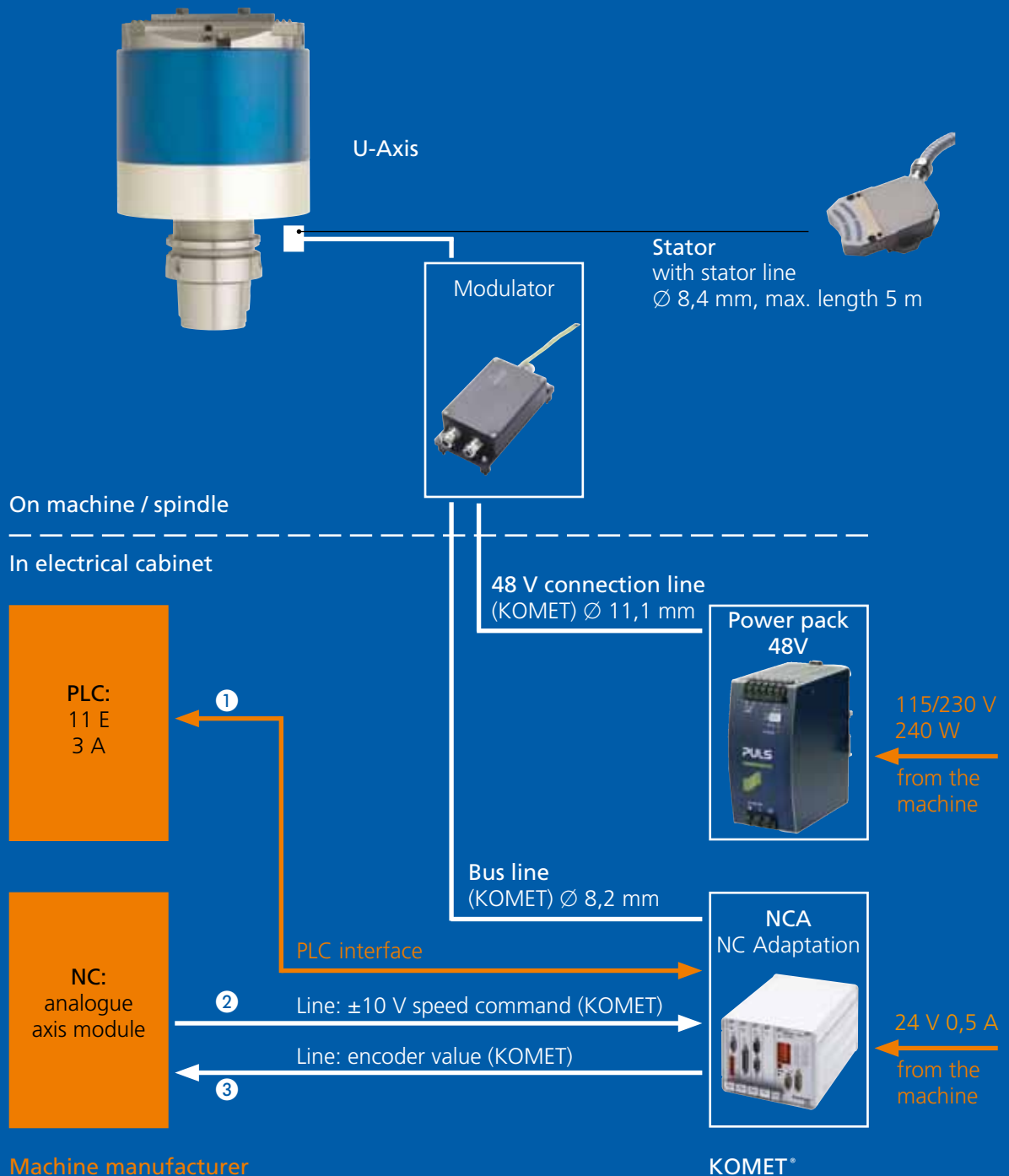

❶ PLC connection

- 11 inputs and 3 outputs are required on the PLC.
- 3 M-commands are required for selecting U-Axis functions.

❷ Nominal value requirement

- ± 10 V nominal speed value from analogue axis module of NC control to the KOMET NCA.

❸ Incremental actual position value

The current position is transmitted from the KOMET NCA to the analogue axis module for the NC control. The following signal forms are available

- TTL level (5 V) in acc. with RS 422, interpolated, square signal form
- 1 Vpp (1 V peak to peak), sine signal form
- 11 μ App (11 μ A peak to peak), sine signal form

The KomTronic® U-Axis system does not need a power unit on the NC control.

KOMET KomTronic® UAS-160

Schematic system overview

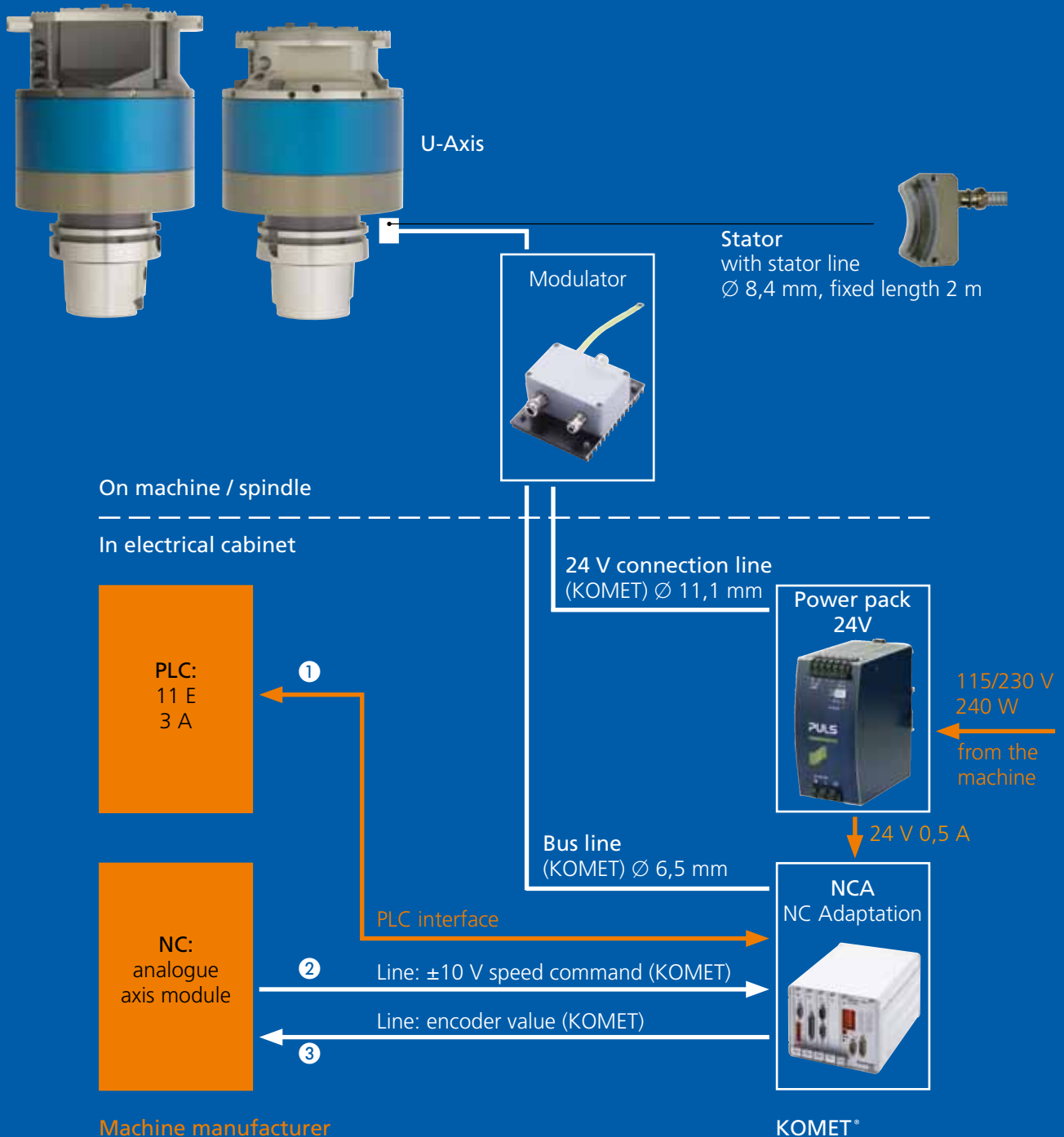

1 PLC connection

11 inputs and 3 outputs are required on the PLC.
3 M-commands are required for selecting U-Axis functions.

2 Nominal value requirement

±10 V nominal speed value from analogue axis module of NC control to the KOMET NCA.

3 Incremental actual position value

The current position is transmitted from the KOMET NCA to the analogue axis module for the NC control. The following signal forms are available

- TTL level (5 V) in acc. with RS 422, interpolated, square signal form
- 1 V_{pp} (1 V peak to peak), sine signal form
- 11 µA_{pp} (11 µA peak to peak), sine signal form

The KomTronic® U-Axis system does not need a power unit on the NC control.

KOMET KomTronic® U-Axis system Installation support by KOMET®

In order to ensure that the KomTronic® U-Axis system is correctly incorporated into the machine and is able to carry out the required functions, the customer must provide clarification and comply with the necessary requirements:

1. Fitting the stator for non-contact power and data transmission to the KomTronic® U-Axis system. Care should be taken to ensure that no conflict occurs with other parts of the machine, the tool changer or similar units. KOMET's obligations do not include provision of the adaptor element for the stator unit.
2. The customer will supply the inputs and outputs required for the KomTronic® U-Axis system on the machine side. The analogue axis unit required for operation with the U-Axis must be provided and configured for the machine control system by the customer.
3. The customer must carry out the necessary software adjustments for the machine sequence control before the installation.
4. Function clarification: Process requirements must be met with reference to machine and processing concept. For example cycle times and machining data must be clarified. The tool changer must be designed for the tool weight and the tool must fit into the tool magazine.

KOMET® will provide the necessary assistance for clarification of the tasks as stated.

Note: The technical notes provided in the application details depend on the environmental and application conditions (such as machine, environmental temperature, lubrication/coolant used and desired machining results): these are based on proper application conditions, use and compliance with the spindle speed limits given for the tools.

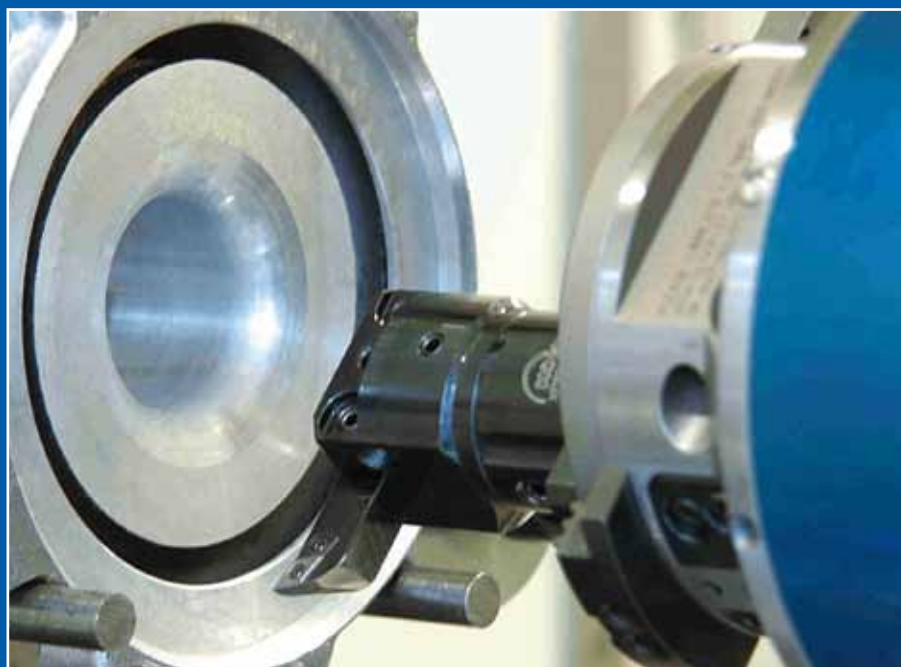

<input type="checkbox"/> Enquiry	Company	
<input type="checkbox"/> Order	Address	
Order No.:	Contact	
Quantity required	Tel.	Fax
	Date	Signature

Requirements for successful project planning for KomTronic® u-axis systems:

Before detailed clarification of the machining task the following questions on the machine and NC control system need to be answered positively.

1. Questions relating to machine

- Can the NC control be fitted with an analogue servo interface ?
- Is the machine manufacturer prepared to adapt the machine ?
 The customer normally needs to ask machine manufacturer to adapt the machine. There will be additional costs for the work carried out by the machine manufacturer. Depending on the age of machines which are already installed, machine manufacturers may not be prepared to carry this out. The PTP method is available for simple feed movements. In this case no analogue servo interface will be required.
- Stator: is there sufficient space on the spindle to fit this ? Check cable length limit 2 m or 5 m. Can tools be automatically changed without colliding with the stator ? Stator holder must be provided by the customer/ machine manufacturer.
- Automatic tool changer: is the changeover weight sufficient ?
 Normally for HSK 100/ISO 50 – machines 25 kg no problem. For HSK 63/ISO 40 machines the changeover weight is sometimes not sufficient. For some applications the changeover speed needs to be reduced. Does the tool fit into the magazine ? Normally adjacent spaces need to be kept free.

Machine	
Spindle connection:	Control system:
Manufacturer:	Control type:
Type:	Control No.:
Machine No.:	Year of machine construction:
Max. change weight::	Maximum permissible tool length?:

2. Questions relating to part being machined

- Is the stroke sufficient for the operation ?
 Range of parts ? If parts of different sizes are to be machined, will the stroke be sufficient for all the parts ?
- Maximum spindle speed ?
 On KomTronic® tool change systems with a single slide, the speed must be reduced as the slide is extended. Rule of thumb for spindle speed: $2500 / \sqrt{\text{stroke}}$. See stroke – spindle speed diagram for tool heads.
- Permissible tool weight and length ?
 No figures defined as yet. These will be calculated by our engineers or trial department.

Parts to be machined	
Surface quality required:	Cpk value:
Tolerances:	Stroke:
Cycle time:	Affecting cycle time?

Machine preparation: See “Requirements for u-axis Installations” and “Conditions”

GERMANY

KOMET GROUP GmbH
Zeppelinstraße 3
74354 Besigheim
Tel. +49(0)7143.373-0
Fax +49(0)7143.373-233
info@kometgroup.com

BRAZIL

KOMET do Brasil Ltda.
Rua Brasileira, 439
07043-010 Guarulhos - São Paulo
Tel. +55(0)11.2423-5502
Fax +55(0)11.2422-0069
info.br@kometgroup.com

GREAT BRITAIN

KOMET (UK) Ltd.
4 Hamel House
Calico Business Park
Tamworth
B77 4BF
Tel. +44(0)1827.302518
Fax +44(0)1827.300486
info.uk@kometgroup.com

JAPAN

KOMET GROUP KK
180-0006
1-22-2 Naka-cho Musashino-shi
Tokyo Japan
Grand Preo Musashino 203
Tel. +81(0)422 50 0682
Fax +81(0)422 50 0683
info.jp@kometgroup.com

AUSTRIA

KOMET GROUP GmbH
Wagramer Straße 173
1220 Wien
Tel. +43 (1) 259 22 04
Fax +43 (1) 259 22 04 76
info.at@kometgroup.com

SWEDEN

Square Tools AB
Box 9177
20039 Malmö
Tel. +46-40-49 28 40
Fax +46-40-49 19 95
info.se@kometgroup.com

CZECH REPUBLIC

KOMET GROUP CZ s.r.o.
Na Hůrce 1041/2,
160 00 Praha 6
Tel. +42(0)2 35 01 00 10
Fax +42(0)2 35 31 18 90
info.cz@kometgroup.com

GERMANY

KOMET GROUP GmbH
Werk Stuttgart-Vaihingen
Ruppmannstraße 32
70565 Stuttgart / Vaihingen
Tel. +49(0)711.78891-0
Fax +49(0)711.78891-11
info@kometgroup.com

CHINA

KOMET GROUP
Precision Tools (Taicang) Co., Ltd.
(Headquarter Asia Pacific)
No. 5 Schaeffler Road
Taicang, Jiangsu Province, 215400
Tel. +86(0)512.535757-58
Fax +86(0)512.535757-59
info.cn@kometgroup.com

INDIA

KOMET Precision Tools India Pvt. Ltd.
16J, Attibele Industrial Area
BANGALORE - 562 107
Tel. +91-80-2807 8000
Fax +91-80-2807 8100
info.in@kometgroup.com

KOREA

KOMET GROUP Precision Tools
Korea Co.,Ltd.
#201, Lotte IT Castle-2, 550-1,
Gasan-dong, Geumcheon-gu,
Seoul, 153-768
Tel. +82(0)2.2082-6300
Fax +82(0)2.2082-6309
info.kr@kometkorea.com

POLAND

KOMET-URPOL Sp.z.o.o.
ul. Przyjaźni 47 b
PL 47-225 Kędzierzyn-Koźle
Tel. +48(0)77.4829060
Fax +48(0)77.4061070
info.pl@kometgroup.com

SWITZERLAND

KOMET GROUP GmbH
Zeppelinstraße 3
74354 Besigheim
GERMANY
Tel. +41(0)62 285 42 62
Fax +41(0)62 285 42 99
info@kometgroup.com

USA

KOMET of America, Inc.
2050 Mitchell Blvd.
Schaumburg
IL 60193-4544
Tel. +1-8 47-9 23 / 84 00
+1-8 47-9 23 / 84 80
Fax +1-8 00-8 65 / 66 38
customerservice@komet.com

FRANCE

KOMET S.à.r.l.
46-48 Chemin de la Bruyère
69574 Dardilly CEDEX
Tel. +33(0) 4 37 46 09 00
Fax +33(0) 4 78 35 36 57
info.fr@kometgroup.com

ITALY

KOMET Utensili S.R.L.
Via Massimo Gorki n. 11
20098 S. Giuliano Mil.
Tel. +39-02-98 40 28 1
Fax +39-02-98 44 96 2
info.it@kometgroup.com

MEXICO

KOMET de México
S. de R. L. de C.V
Acceso 1 Nave 8 No. 116
Fraccionamiento Industrial La Montaña
Querétaro, Qro.
C.P 76150 México
Tel. +52-442 2-18-25-44
Fax +52-442 2-18-20-77
info.mx@kometgroup.com

RUSSIA

KOMET GROUP GmbH
ul. Spartakovskaya, 2V
420107, Kazan
Tel. +7 843 5704345
Fax +7 843 2917543
info.ru@kometgroup.com

SPAIN

KOMET IBERICA TOOLS, S.L.
Av. Corts Catalanes 9-11
Planta baja, local 6B
08173 SANT CUGAT DEL VALLES
Tel. +34-93-583.96.20
Fax +34-93-583.96.12
info.es@kometgroup.com

www.kometgroup.com