





JEL[®] JSF
Synchro tapping chuck

JEL® JSF Synchro tapping chuck

- with ISO 12164-1 HSK-A and
cylindrical shank DIN 1835

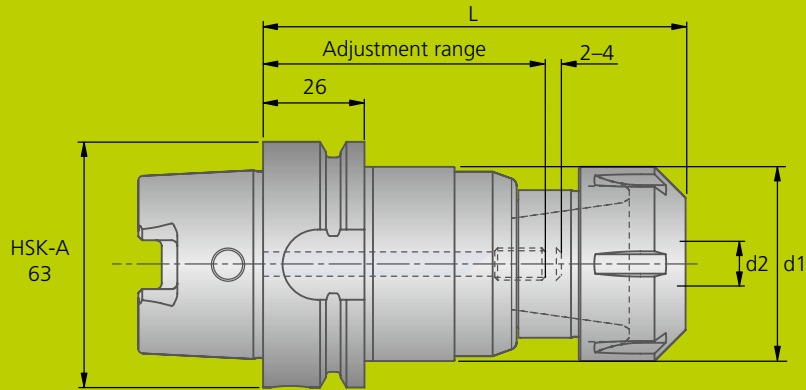
- internal coolant supply (max. 50 bar)
- MQL 1-channel system



JSF HSK-A								Accessory	
for thread	Article	Order No.	HSK-A d	d1	Clamping range for collet d2	L		Collet with square drive Size	Seal disc for collet nut Size
M4 – M12	JSF-HSK-A63-20-96	5079502 6002000	63	34	4,5 – 11,2	96	0,98	ER20	DS/ER20
M4 – M20	JSF-HSK-A63-32-109	5079502 6003200	63	50	4,5 – 18,0	109	1,48	ER32	DS/ER32
M4 – M12	JSF-HSK-A63-20-160	5079602 6002000	63	34	4,5 – 11,2	160	1,40	ER20	DS/ER20

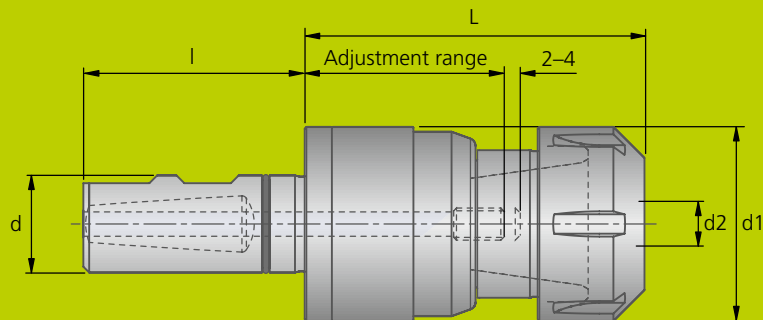

JSF cylindrical shank								Accessory	
for thread	Article	Order No.	Cylindrical shank d x l	d1	Clamping range for collet d2	L		Collet with square drive Size	Seal disc for collet nut Size
M4 – M12	JSF-ZS1835-20-71	5079500 4002000	25 x 57	34	4,5 – 11,2	73	0,54	ER20	DS/ER20
M4 – M20	JSF-ZS1835-32-88	5079500 4003200	25 x 57	50	4,5 – 18,0	87,5	0,65	ER32	DS/ER32

Length adjustment 2 – 4 mm

Supply includes:

Synchro tapping chuck with coolant tube, screw set and key.

Please order separately: collet with square drive and seal disc for collet nut.

JEL® JSF Synchro tapping chuck



Modern CNC machines allow synchronous thread tapping without a compensating chuck, also called „rigid tapping“.

The backlash of the spindle causes stress to one side of the cut tap or form tap, respectively. This may result in a reduced tool life and lack of quality in the surface of the thread.

JEL synchro tapping chucks compensate for the length errors caused by the backlash and create the prerequisites for achieving optimum performance from your tapping tools.



Benefits for you:

- Optimum tool performance
- Maximum tool life
- Can be used with internal coolant supply or MQL 1 channel system

			ER20		ER32	
			Collet with square drive	Seal disc for collet nut	Collet with square drive	Seal disc for collet nut
d×SW	l	Standard	Order No.	Order No.	Order No.	Order No.
4,5×3,4	14/18	DIN	52805 20045	52806 20045	52805 32045	52806 32045
5,5×4,3	18	DIN	52805 20055	52806 20055		
6,0×4,9	18	DIN	52805 20060	52806 20060	52805 32060	52806 32060
7,0×5,5	18	DIN	52805 20070	52806 20070	52805 32070	52806 32070
8,0×6,2	18	DIN	52805 20080	52806 20080	52805 32080	52806 32080
9,0×7,0	22	DIN	52805 20090	52806 20090	52805 32090	52806 32090
10,0×8,0	22	DIN	52805 20100	52806 20100	52805 32100	52806 32100
11,0×9,0	25	DIN	52805 20110	52806 20110	52805 32110	52806 32110
12,0×9,0	25	DIN			52805 32120	52806 32120
14,0×11,0	25	DIN			52805 32140	52806 32140
16,0×12,0	25	DIN			52805 32160	52806 32160

GERMANY

KOMET GROUP GmbH
Zeppelinstraße 3
74354 Besigheim
Tel. +49(0)7143.373-0
Fax +49(0)7143.373-233
info@kometgroup.com

GERMANY

KOMET GROUP GmbH
Werk Stuttgart-Vaihingen
Ruppmannstraße 32
70565 Stuttgart / Vaihingen
Tel. +49(0)711.78891-0
Fax +49(0)711.78891-11
info@kometgroup.com

BRAZIL

KOMET do Brasil Ltda.
Rua Brasileira, 439
07043-010 Guarulhos - São Paulo
Tel. +55(0)11.2423-5502
Fax +55(0)11.2422-0069
info.br@kometgroup.com

CHINA

KOMET GROUP
Precision Tools (Taicang) Co., Ltd.
(Headquarter Asia Pacific)
No. 5 Schaeffler Road
Taicang, Jiangsu Province, 215400
Tel. +86(0)512.535757-58
Fax +86(0)512.535757-59
info.cn@kometgroup.com

FRANCE

KOMET S.à.r.l.
46-48 Chemin de la Bruyère
69574 Dardilly CEDEX
Tel. +33(0) 4 37 46 09 00
Fax +33(0) 4 78 35 36 57
info.fr@kometgroup.com

GREAT BRITAIN

KOMET (UK) Ltd.
Unit 4 Triton Park
Brownsover Road
Swift Valley
Rugby, CV21 1SG
Tel. +44(0)1788.5797-89
Fax +44(0)1788.5797-90
info.uk@kometgroup.com

INDIA

KOMET Precision Tools India Pvt. Ltd.
121/B, Bommasandra Industrial Area
BANGALORE - 560 099
Tel. +91-80-27834821
Fax +91-80-27834495
info.in@kometgroup.com

ITALY

KOMET Utensili S.R.L.
Via Massimo Gorki n. 11
20098 S. Giuliano Mil.
Tel. +39-02-98 40 28 1
Fax +39-02-98 44 96 2
info.it@kometgroup.com

JAPAN

KOMET GROUP KK
180-0006
1-22-2 Naka-cho Musashino-shi
Tokyo Japan
Grand Preo Musashino 203
Tel. +81(0)422 50 0682
Fax +81(0)422 50 0683
info.jp@kometgroup.com

KOREA

KOMET GROUP Precision Tools
Korea Co.,Ltd.
#201, Lotte IT Castle-2, 550-1,
Gasandong, Geumcheon-gu,
Seoul, 153-768
Tel. +82(0)2.2082-6300
Fax +82(0)2.2082-6309
info.kr@kometkorea.com

MEXICO

KOMET de Mexico
S. de R. L. de C.V
Acceso „A“, No. 110
Parque Industrial Jurica,
76120, Queretaro, Qro. Mexico
Tel. +52-442 2-18-25-44
Fax +52-442 2-18-20-77
info.mx@kometgroup.com

AUSTRIA

KOMET GROUP GmbH
Wagramer Straße 173
1220 Wien
Tel. +43-1-2 59 22-04
+43-1-2 59 22-12
Fax +43-1-2 59 22 12-76
info.at@kometgroup.com

POLAND

KOMET-URPOL Sp.z.o.o.
ul. Stoczniewców 2
47-200 Kędzierzyn-Koźle
Tel. +48-77-482 90 60
Fax +48-77-406 10 70
info.pl@kometgroup.com

RUSSIA

KOMET GROUP GmbH
ul. Spartakovskaya, 2V
420107, Kazan
Tel. +7 843 5704345
Fax +7 843 2917543
info.ru@kometgroup.com

SWEDEN

Square Tools AB
Box 9177
20039 Malmö
Tel. +46-40-49 28 40
Fax +46-40-49 19 95
info.se@kometgroup.com

SWITZERLAND

KOMET DIHART AG Precision Tools
Industriestrasse 2
4657 Dulliken
Tel. +41(0)62.2854-200
Fax +41(0)62.2854-202
info.ch@kometgroup.com

SPAIN

KOMET IBERICA TOOLS, S.L.
Av. Corts Catalanes 9-11
Planta baja, local 6B
08173 SANT CUGAT DEL VALLES
Tel. +34-93-583.96.20
Fax +34-93-583.96.12

CZECH REPUBLIC

KOMET GROUP CZ s.r.o.
Na Hůrce 1041/2,
160 00 Praha 6
Tel. +42(0)2 35 01 00 10
Fax +42(0)2 35 31 18 90
info.cz@kometgroup.com

USA

KOMET of America, Inc.
2050 Mitchell Blvd.
Schaumburg
IL 60193-4544
Tel. +1-8 47-9 23 / 84 00
+1-8 47-9 23 / 84 80
Fax +1-8 00-8 65 / 66 38
customerservice@komet.com

www.kometgroup.com