

KPLUS

A technical magazine from KOMET INDIA

TOOLS + IDEAS®

The power of innovation

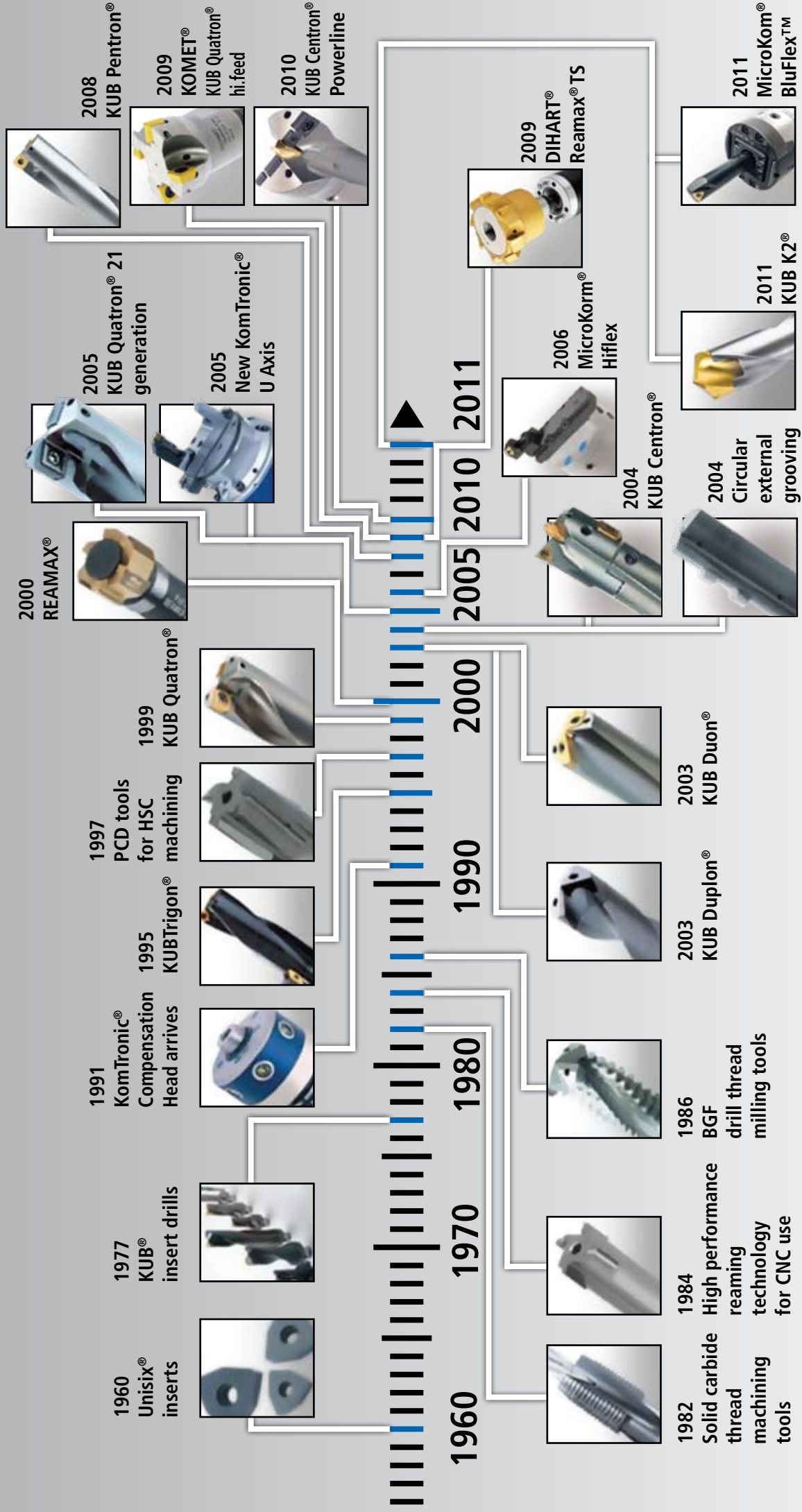

02

The power of innovation



04

Evolution of Drilling



06

Challenges - Power Sector



08

Managing Growth



09

Drill Plus Mill

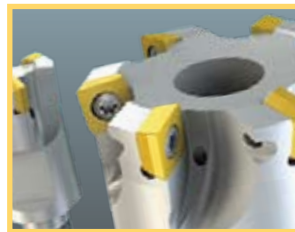

10

Kom News



Message, KOMET GROUP

India continues to be an important market for KOMET GROUP. There is great amount of urge among Indian Manufacturers to be updated with recent innovations. Through this magazine we endeavor to bring you our new products and solutions which we offer to our customers across Globe.

We hope that you will find this magazine interesting and useful.



KOMET GROUP management

Dr. Christof Bonsch *Matthias Heinz*
Dr.Christof Bonsch Matthias Heinz

Message, KOMET INDIA

Today, new manufacturing techniques and technologies get outdated in seconds, but the passion to excel and innovate remains.

You hold in your hands the first edition of KPLUS, a technology magazine from KOMET India. The newsletter that showcases Next Generation cutting tool solutions offered by KOMET India, your hole making solution provider. With fire in our belly, backed by knowledge to offer you always more than just tools.

This first edition is dedicated to our core product, the Drills' family which includes solid carbide /indexable drills starting from diameter 3mm to 155mm.

This edition also brings to your reading table some of our many success stories; accounts that highlight our passion and knowledge that helped companies reduce cost and improve productivity.

I hope you find this issue beneficial and interesting for your business needs.



S. Ravishankar
S. RAVISHANKAR
Managing Director

EVOLUTION OF DRILLING

Drilling is the most productive method to make a hole, but this operation has become extremely complex during the past few decades. The increasing demands of productivity, cost savings, and widespread usage of heat-resistant materials, such as Inconel, Rene, Hastelloy, Titanium, and so on in aerospace applications has resulted in the growing complexity of drilling. These metals pose new challenges for drilling. To ensure success with exotic materials and to maximize tool life, drilling experts always look out for ways to improve everything from cutting tool materials, coolants, holding mechanisms, coatings, and new geometries.

The typical types of drills are HSS - drills, Brazed Carbide drills, Solid carbide drills, Indexable Insert drills, Gun drills, PCD drills, and Deep hole drills.

HSS drill developed in late 1800's is considered to have revolutionized cutting technology. HSS Drills were called high speed steels because they could operate at higher cutting speeds of 8 – 30 mtrs/min when compared to low and medium carbon steels. They could be used on SPMS and on all possible component materials.

But with the development of solid carbide drills in early 1920s the cutting speeds increased dramatically

to 150 mtrs/min. The tool life became longer, lasting 3 to 10 times more than HSS drills, positional and dimensional accuracy improved, and also the quality of the drilled holes increased to IT7 – IT9. But the main disadvantage of solid carbide drills is that they are costly and brittle in nature to handle torsional forces.

These disadvantages of HSS and solid carbides led to the birth of indexable drills with steel body and indexable inserts. These drills use cemented carbide inserts thereby eliminating the need of having an entire tool body made of tungsten carbide. This reduces the tool cost considerably. And by relying on indexable inserts, manufacturers can avoid Solid Carbide drill reconditioning process, which is both costly and time consuming. Indexable carbide inserts, have multiple cutting edges which can be quickly rotated to provide a fresh cutting edge. So, rather than switching out the entire solid drill, carbide inserts can be indexed up to 4 times before being swapped out for fresh inserts. Indexable drills with steel body can handle torsional forces, and carbide inserts with multiple cutting edges helps in cost reduction. These drills are ideal for medium and large diameter holes with medium tolerance demands.

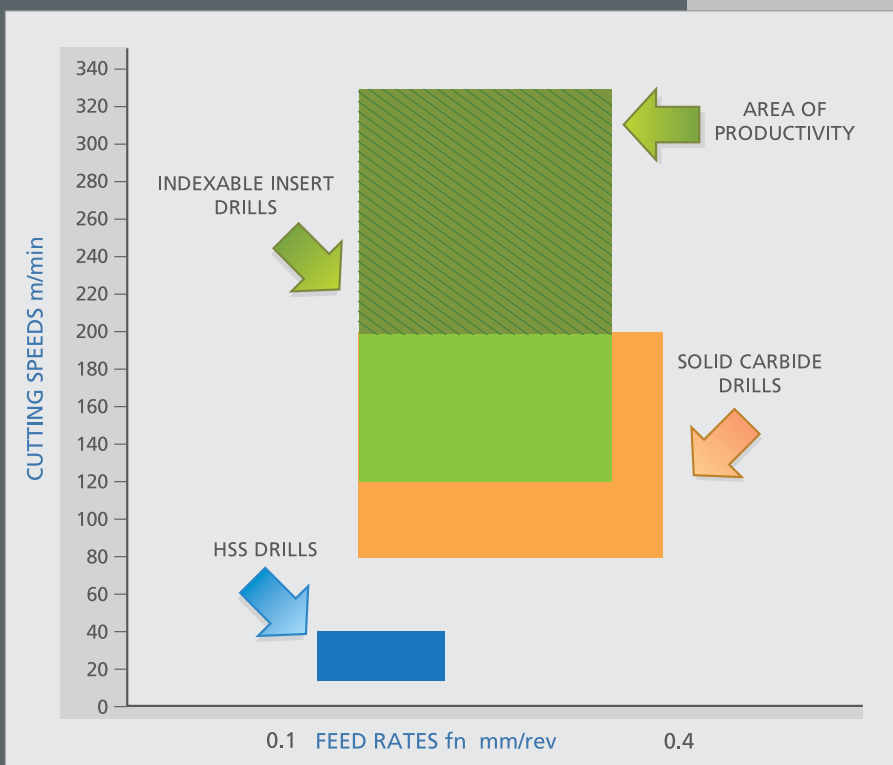

The diagram here shows comparison in terms of cutting speeds and feed rates for HSS, Solid carbide and Indexable drills.

KOMET GROUP has been revolutionizing Indexable drilling technology since 1977 with continuous innovation to bring out high performance and advanced drilling solutions. Our drilling systems are successfully being used by our delighted customers across the globe.

Indexable drill performance has been enhanced over the years through the usage of new carbide coatings for inserts and drill, new insert geometries, and multiple cutting edges. In general, carbide insert is considered a piece of hard metal. But it carries a lot of know-how and technology for choosing the optimum carbide substrate with combined hardness and toughness. KOMET has been driving continuous improvement in insert technology by upgrading the new grades. These new grades offer combined hardness and toughness through new substrates and multi-layer CVD and PVD coatings. It is not just the substrate and the coatings alone, but also the edge preparations "Strengthened cutting edge", new innovative chip breaking geometries like "03" and "13" that bring tremendous benefits to high performance drilling in increasing the tool wear resistance. With constant research and development happening on cutting materials and geometries, further productivity improvements and cost savings is a sure possibility.



Performance Comparison - At a Glance

	HSS	Solid Carbide	Indexable
Parameters (Vc & Fn)	+	+++	+++
Productivity	+	+++	+++
Accuracy (Tolerance)	+	+++	++
Cost/Tool	+	+++	++
Machining Cost/Comp	+++	++	+
+ Low ++ Medium +++ High			



KOMET KUB K2®

CHALLENGES - POWER SECTOR

// Electricity consumption in India is currently 600 Tera Watt hour (TWh) annually and is set to double by next decade."

Indian power sector has registered considerable progress pro- independence. Hydro -power and coal based thermal power has remained as our backbone for generating electricity. The development of Nuclear power and renewable energy has relatively been at slower pace, but very much required for accelerated growth of power sector. In order to bridge India's supply - demand gap, total generating capacity should jump from 90 giga watt (GW) to 241 GW, with an increased emphasis on nuclear, clean coal and renewables including wind power, solar, and small-hydro.

Manufacturing and Power sector

The complexity of machining of Power sector parts is mainly derived from its shapes and sizes. The typical parts to name are Turbine housing Lower and Upper half, Rotor shaft, Turbine blades, Valves and so on. The complexity starts right from Loading Part on machine and choosing the right and robust clamping method. This clamping should be able to withstand Heavy machining involving huge proportion of Milling and drilling process. The challenges for cutting tool manufacturers is:

- To reduce the "Machining time"
- To help reduce the setup time

The hole making process consumes major time in case of turbine housing and rotor shaft, these holes are large in nature and are produced using conventional HSS Drills in several steps using multiple drills from smaller to larger diameter to reach the final desired diameter. This process is quite slow and takes longer machining time.

The typical Mounting Holes of Turbine housing is shown below. These holes involve drilling and back spot facing with interrupted conditions.

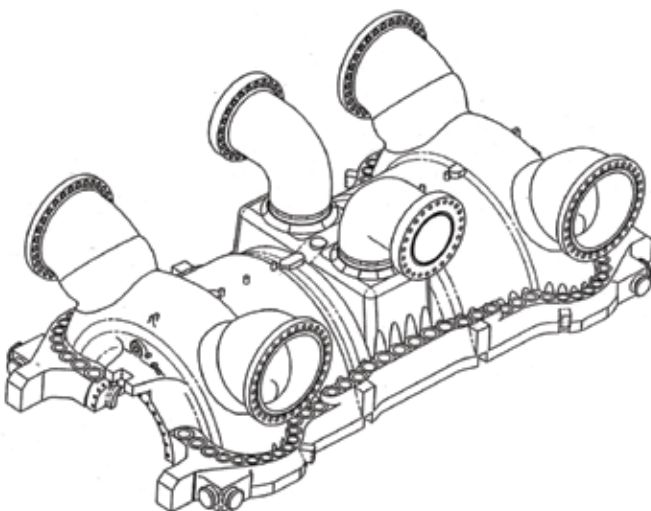

Over several decades KOMET GROUP has been innovative and successful in bringing out performance drilling solutions especially in machining of complex turbine parts. The key product lines are:

- KUB Centron® drills for deep hole drilling
- KUB® Modular V464 drills for larger diameters
- The new KUB Centron® power line for high feed rates.

THE KUB Centron®: The Problem solver for deep hole drilling



KUB Centron® is designed for offering maximum Drilling Performance and Dimensional Accuracy at Drilling Depths of up to 9xD.

- These drills are available in diameter ranges from dia 20 to 160 mm
- Modular replaceable drill head on basic element
- The unique advantage here is Drilling in one go with cutting speeds of 180 mtrs to 300 mtrs/min
- Drill diameter adjustment is available from 65mm to 160mm

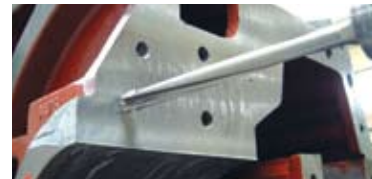

KUB Centron® " at work" on a turbine housing on Horizontal boring machine.

KUB® V464 – Modular Drills – Dia 80 – 160 mm



Flexible yet high performance drilling solution for larger diameters; KUB® V464 is available with modular connectivity that can be built with KOMET ABS® Modular system, depending on depth of the drilling. The diameter of the drill head is adjustable in the range of 5 mm.

The below exhibit shows fitting hole drilling using a 86mm Dia V464 on alloyed material GS 17 Cr Mo V 55at a cutting speed of 187 m/min and feed of 0.12mm/rev

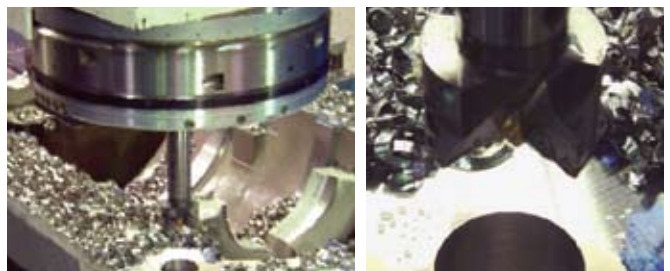

The new KUB Centron® Powerline : Hammer Down up to 9xD



The born tough; new KUB Centron® Powerline is designed to offer maximum Drilling Performance. The twin cutting edges on the drill body, doubles the

feedrates with KOMET High performance Quatron- 4 Real usable cutting edge inserts. This ensures maximum stability and optimum chip removal, even at maximum drilling depths. The new drill head offers unbeatable drilling performance by reducing the machining time to half of normal. The cutting division per side (from x 39 mm) allows short chips to be produced even on extremely poor for machining materials.

Available from diameter 20 to 81mm, Centron Powerline enables drilling up to 9xD on flat surfaces even without a pilot hole. The New Centron drill is a major innovation milestone of KOMET Group; focused on improving "Productivity" of Deep hole drilling operations across all Energy sector components.

YOUR +

SUCCESS STORY OF KUB V464 – Modular drilling on Turbine Housing

- Application : Dia 90 Drilling x 150 mm deep (Mounting Holes)
- Number of Holes : 48
- Machine : Horizontal Boring Machine
- Component : Turbine housing- lower Half
- Old method/Process : HSS Drills in multiples of drilling diameter; from smaller to bigger in order to reach final diameter
- Machining time with Old process : 112 Hours (14 Shifts)



Typical turbine housing

KOMET Solution:	Vc = mtrs/min	Spindle speed RPM	Feed = mm/rev	Feed = mm/min	Machining time in minutes
Drilling dia 89.5 mm	80	285	0.08	23	7.6
KUB V464 - Drill Dia 89.5 mm V46 40851 - Drill Head A20 00250 - Extension A20 1045 - Reducer ABS63/ABS50 A50 00860 - ISO50 /ABS63 adaptor with coolant ring W29 34130.0484 (x4) Inserts					
Dia 90 Boring to finish size	120	427	0.08	34	5.4
B30 05010 - Boring head M30 02321- Fine boring cartridge W57 26040.0432- Cermet inserts					

Total Machining time per hole	13.0
Total Machining time 48 holes	623
Number of shifts	1.3
Old process time (in shifts)	14
Reduction in machining time by	91%

Productivity up by 10 times

Watch out for more success stories on complex Power sector components in our next edition.

MANAGING GROWTH



Rebound in global economy during last year has changed the dynamics of Indian manufacturing industry. Despite recession fears in US and global markets, Indian growth story remains intact. The common question today is "How to Manage the Growth"?

Traditionally, Indian manufacturing industries grew with the idea of self-reliance, to develop in-house skills for non-core activities. This was mainly due to lack of expertise/adequate support from reliable suppliers/service providers. Industry used to develop its own tools, fixtures and other non-core activities. Thus the focus on non-core activities consumed critical resources.

But will sticking to Core Competence alone ensure the "Management/sustenance of Growth"? The answer is a likely "no". Industry needs to reinvent itself across lines by reducing costs, adopting cutting edge technology, following best management practices, keeping customer as the focal point, and espousing the best practices from other sectors.

With increasing cost of material and labor and reducing price levels due to competition, the Industry needs to constantly improve efficiency and reduce cost of manufacturing. Today when one speaks about keeping costs under constant check, reduction in cost of raw material and other consumables is given more

impetus. But we should also ensure that this buoyant reduction in material cost does not wean away our focus from improving

the quality of our products and continuous improvisation of reliable processes and equipments. India Inc requires a paradigm mind shift in this direction.

With the speeding up of this growth engine people related issues arise. People move frequently across all latitudes and

longitudes which result in huge experience but low competence and knowledge. Focus must shift to selection competent professionals rather than experienced people.

Managing growth won't happen unless we acclimatize ourselves to new management practices. Every other day we talk about lean manufacturing, frugal engineering and other concepts. The companies that have implemented and meticulously put to practice these concepts have hugely benefited from these practices.

Finally, for sustaining and propelling this growth engine, organizations need to fine tune their organization culture with changing technology and keeping Customer First mentality. When this happens all other best practices such as delivering superior quality, continuous research and development, and constant innovation will fall in line.

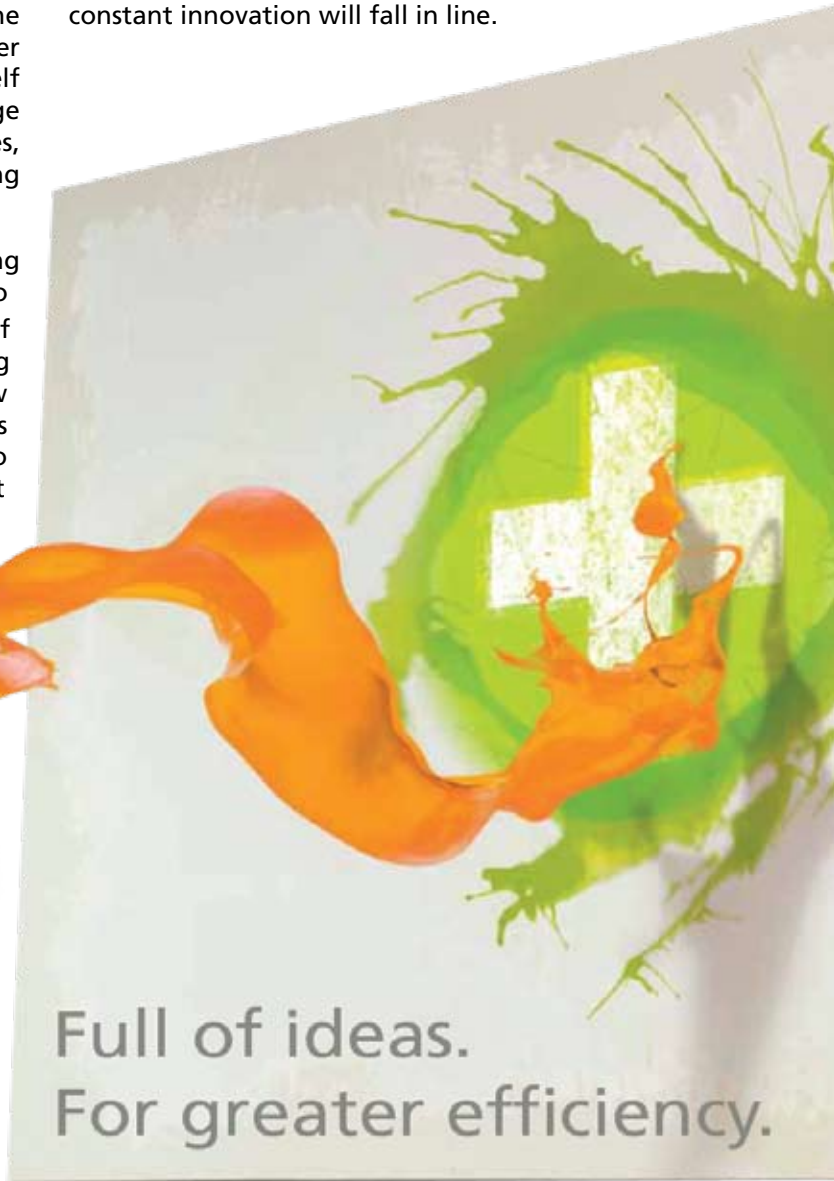
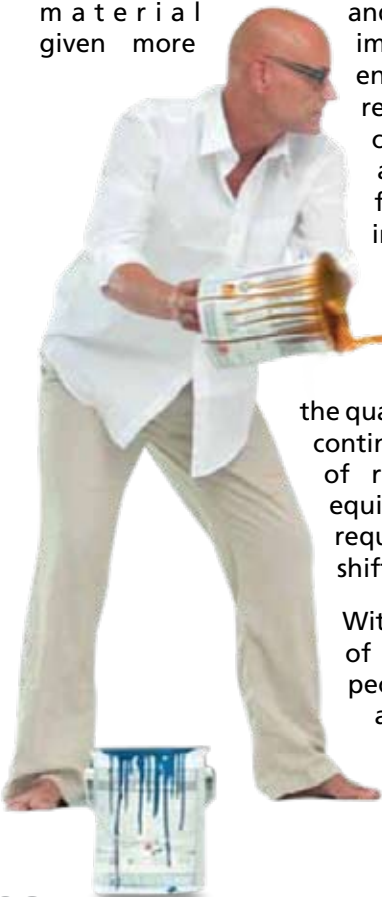

Full of ideas.
For greater efficiency.

DRILL PLUS MILL

KOMET GROUP - the technology harbinger in precision machining industry has come up with a unique idea of using drilling insert for high feed milling process.



OUR IDEAS

- Common inserts for drilling and milling.
- 4 edge economy.
- Proven Quatron insert with universal grade & geometry.
- Cutter range from Dia 20 to 52.
- Feed up to 2mm/tooth.
- Modular screw on coupling and Face Mill arbor mounting.
- Hardened and coated cutter body.

KOMET has succeeded in extending its tried and tested KUB Quatron® inserts to new Quatron high feed milling cutters. Thereby giving customers to use the common inserts for both the application.

The unique Quatron inserts developed from solid drilling technology is offering high feed metal removal in milling operation.

Drilling + Milling

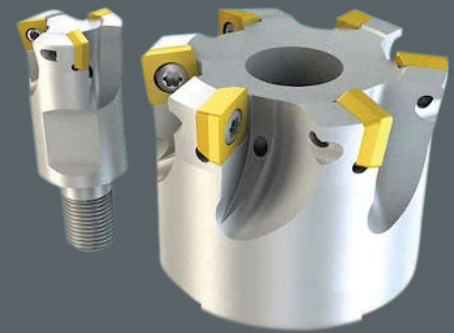

High feed milling and plunge millings are relatively new machining methods used for deep cavity machining, particularly in the Die & Mould industry. These methods are now widely accepted as a high feed face milling operation too. Plunge milling can be the ideal solution for unstable machining setups and low power machining centers.

YOUR PLUS

- Fewer inventories.
- Better cost economics.
- Wide range of solutions.
- Higher metal removal & better productivity.
- No additional investment for holding.
- Better process stability and improved tool life.

Large bore machining is now made easy with one single tool, rather than using several drilling/boring tools especially on low power machining centers with helical interpolation methods. This highly productive machining method not only improves the metal removal rate, but also exerts less pressure on machine spindle.

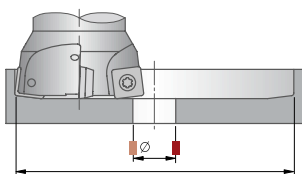

Circular interpolation

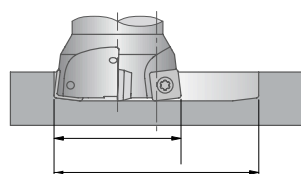

Milling into solid material

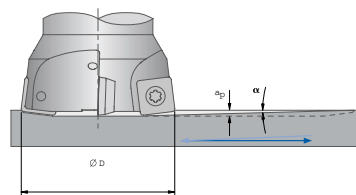

Inclined plunging

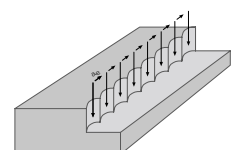

Plunge milling



KOMET GROUP launches investment offensive

Construction begins on a state-of-the-art logistics centre at Besigheim site.

The **KOMET GROUP** has emerged from the recession even stronger than before and is planning a large-scale investment offensive for implementation over the next few years. The company is investing further in its Besigheim site, with the construction of a new, state-of-the-art logistics centre.

“We are investing for the benefit of our customers and our aim is to speed up our processes”, says Dr Christof Bönsch, managing director of the **KOMET GROUP**, explaining the reasoning behind the large-scale offensive. By cutting back on the individual handling stages, the plan is to reduce the processing time required for incoming orders. The logistics centre, which will be equipped with state-of-the-art technology, will cover 400 m², providing space for around 15,000 items from the **KOMET**, **DIHART** and **JEL** product ranges. “The use of state-of-the-art warehouse technology and high-performance EDP equipment will vastly reduce our ongoing operating cost and inventory expenditure”, adds Matthias Heinz, also a managing director of the **KOMET GROUP**.

The new logistics centre will be built as an extension to the existing building on the factory premises.

The construction of the new logistics centre is merely the prelude to a whole series of further investments. Over the next few years, the **KOMET GROUP** plans to invest over 50 million euro in machinery and equipment in order to reinforce its leading position in the field of precision tools.

IDEEN-FABRIK

The IDEEN-FABRIK+ represents the evolution of the **KOMET GROUP** from a tool manufacturer into a creative expert for solutions covering every aspect of drilling, thread milling, reaming and mechatronic tools. With a total area of 2,500 m², we have created a modern factory environment which allows plenty of free room for creative work and learning. The IDEEN-FABRIK+ has been deliberately constructed not as a separate training building, but as an integrated facility directly above the production operations. The work is therefore combined at all times with new ideas and creative ambition.

With the IDEEN-FABRIK+ and the comprehensive seminar program for customers and employee qualification, we offer a measurable, long-term competitive advantage individually tailored to you and your market.



**The strategy.
For more performance.**



**KUB Centron[®]
Powerline**

KUB Quatron[®]

KUB Pentron[®]

KUB K2[®]

Innovative tool concepts and complete solutions for bore machining – these are our core areas of expertise. Here we are the world technology leader as a manufacturer of premium tools. Here we offer a plus in support and services.

We call this TOOLS PLUS IDEAS; our customers know it as the KOMET GROUP.

**KOMET Precision Tools
India Pvt Ltd.**

16J, Attibele
Industrial Area
Bangalore-562 107 India
Tel: +91(0)80-2807 8000
Fax: +91(0)80-2807 8100
www.kometindia.com
info@kometindia.com

Distributors invited

Please contact
sarath.nair@kometgroup.com

KOMET PRECISION TOOLS PVT LTD

16 J Attibele Industrial Area
Bangalore - 562107
Tel: +91 080 28078000
info.in@kometindia.com

KOMET'S STATE-OF-THE-ART MANUFACTURING FACILITY inaugurated in 2009

**BRANCHES**

New Delhi - 110 087
+ 91 98108 08322
sjs@kometindia.com

Chennai - 620041
+ 91 9600 048615
n.somasundaram@kometgroup.com

Pune - 411 012
+ 91 99700 94425
sbg@kometindia.com

Bangalore - 562107
080 2807 8000
info.in@kometindia.com

NETWORK

Aakar Engineers
Indore
+91 0731 2532422

Fine Product Enterprises
Pune
+91 020 46703460

Kalp Technovision
Ahmedabad
+91 079 25632246/27560238

Nano Tools
Chennai
+91 044 26510044

Rasita Enterprises
Kolhapur
+91 0231 2672527

Tekno Corp
Secunderabad
+91 9701018786, 9000575533

Abhishek Engineers
Vadodara
+91 0265 2657859/2646171

IL Industrial Traders
Gurgaon
+91 0214 4366519

K S Agencies
Coimbatore
+91 0422 2232599

Nigel Products
Trichy
+91 9036068496

Saluja Machinery Co.
Kanpur
+91 512 3014625/3016671

Tool Tech
Coimbatore
+91 0422 4213371/4213372

Classic Marketing
Nagpur
+91 0712 2461551

Industrial Support Systems
Haridwar
+91 01334 227656/222656

Moxie Engineering Pvt. Ltd.
Ludhiana
+91 0161 2681125

Om Cam
Mumbai
+91 022 26786032

Tech Tools
Vadodara
+91 0265 2341605

Glenz Tech (India)
Gurgoan
+91 124 4366519